



CF Range



CF Range

The CF Range offers full automation of sample processing and is offered in two models; CF1 and CF2 dependant on the customers volumes.

The CF1 model is a table-top system that will process up to 6 L/hr (power dependant) and is ideal for customers working with volumes above 80 mL. A process pump can be fitted to this system so customers do not have to manually refill the reservoir after each 200 mL.

The CF2 model is a floor standing system that will process 24 L/hr and is ideal for customers working with volumes above 10 L. A process pump is fitted as standard to this system.

Should customers wish to process smaller samples, Constant Systems Ltd recommends using the One Shot Head Adaptor which will allow customers to process up to 10 mL of solid, liquid or frozen samples in each shot.

Lysis Efficiency of Bacteria, Yeast and Algae by Constant Systems Continuous Flow Cell Disruptor in Standard Configuration

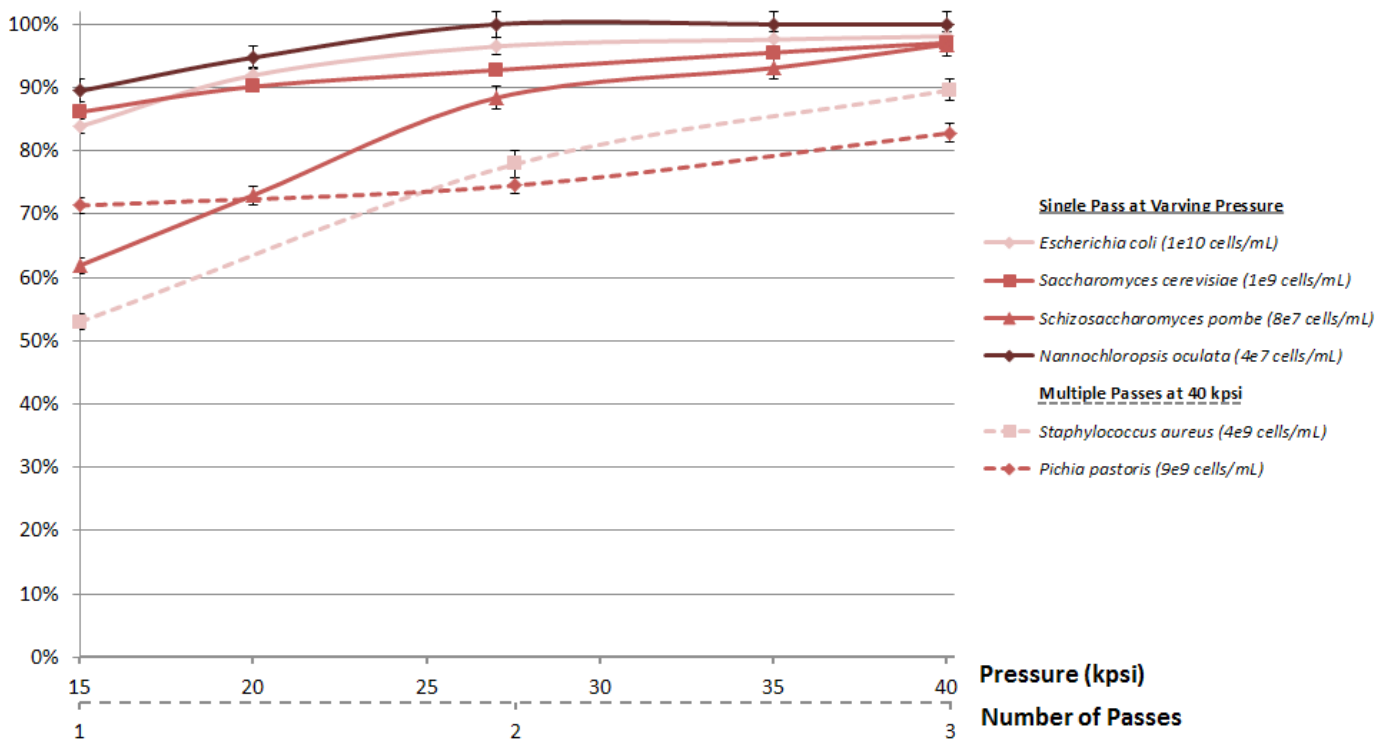

Specifications

- Quick and easy to use.
- No need for compressed air or bottled gas, simply plug in and switch on
- No need to prime
- Disruption pressure displayed digitally and is easily and accurately set between 1-40kpsi as standard
- Touch screen control
- Automatic shutdown once the sample has been fully processed
- Unique cooling jacket surrounds the disruption head allowing customers to fit a cooling medium to the disruption head for temperature control
- The unique disruption head design ensures that consistency is maintained after each process giving you confidence in repeatability
- Fully contained with optional extras
- Clean the system in the same way you process your sample or reverse flow cleaning can also be achieved. Disruption head can be easily dismantled for autoclaving or manual cleaning if required
- CIP and SIP options available upon request
- IQ and OQ available upon request
- Disruption head mounted on a stainless steel tray to capture any spills.
- Materials in product path, 316L and F51 duplex stainless steel or equivalent, EPDM, GLFPTFE and PEEK 450G and WC
- CF1

Unit Dimensions: 605x700x740 mm (DxWxH)

Unit Weight: 130 kg

Phase: 1Ph electricity as standard. 3Ph can be requested for North/South America & Taiwan to increase flow rate from 2.4 L/hr to 6 L/hr.

- CF2

Unit Dimensions: 720x700x1340 mm (DxWxH)

Unit Weight: 240 kg

Phase: 3Ph electricity

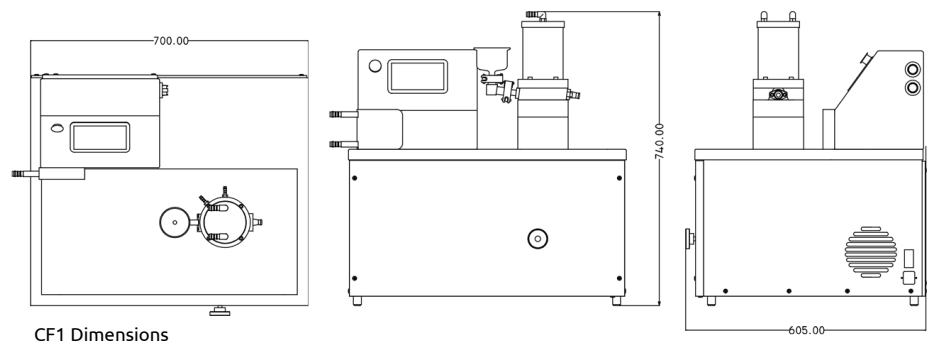

CF1 Dimensions



Cell Disruption Made Easy

Constant Systems Limited
Low March
Daventry
Northants
NN11 4SD
England
UK

Tel: +44 (0) 1327 314146
Email: sales@constantsystems.com